

3-phase Sensor-less Fan Motor Driver

AM8919

The AM8919 is a 3-phase sensor-less DC fan motor driver IC. It senses the BEMF (Back Electro-Motive Force) of the motor in rotation and provides corresponding commutation current to the motor. Rotation speed can be controlled by PWM input signal. The drivers include Lock Detection, Thermal Shutdown, and Over-current limiter. Maximum output current is 1000mA.

● Features

- | | |
|--|---|
| 1) Operation voltage 3.3 to 15V | 7) Over current limiter |
| 2) Direct PWM speed control | 8) Over-voltage protection |
| 3) Built-in FG & RD | 9) Thermal shutdown protection |
| 4) Soft start function | 10) Soft switching technique to reduce acoustic noise |
| 5) Forward and Reverse control | |
| 6) Lock detection/Automatic restart function | |

● Absolute Maximum Ratings (Ta = 25°C)

Parameter	Symbol	Limits	Unit
Supply voltage	V_{CC}, V_M	16	V
VREG strength voltage	V_{REG}	6	V
Output current	I_o	1000	mA
FG & RD output voltage	$V_{FG} \& V_{RD}$	V_{CC}	V
FG & RD output current	$I_{FG} \& I_{RD}$	10	mA
PWM & F/R strength voltage	$V_{PWM} \& V_{FR}$	V_{CC}	V
CSOFT & OSC strength voltage	$V_{CSOFT} \& V_{OSC}$	V_{REG}	V
Power dissipation (JEDEC 2S2P)	P_d	3790*	mW
Operate temperature range	T_{opr}	-40 ~ +95	°C
Storage temperature range	T_{stg}	-55 ~ +150	°C
Junction temperature	T_{jmax}	150	°C

* P_d de-rated by 30.32mW/°C over 25°C (based on JEDEC 2S2P board)

Those are stress rating only and functional operating at those conditions for extended periods may damage to the device.

● Recommended operating conditions

(Set the power supply voltage taking allowable dissipation into considering)

Parameter	Symbol	Min	Typ	Max	Unit
Operating supply voltage range	V_{CC}		3.3~15		V

● Storage Condition

Parameter	Value	Unit
Temperature condition Before Opening	5~40	°C
Humidity condition Before Opening	30~80%	RH
Temperature condition after Opening	<30	°C
Humidity condition after Opening	<60%	RH

● **Electrical Characteristics**

(Unless otherwise specified, $T_a = 25^\circ\text{C}$, $V_{CC} = 12.0\text{V}$)

Parameter	Symbol	Limit			Unit	Conditions
		Min	Typ	Max		
Supply current	I_{CC}	—	1.8	3	mA	PWM= V_{REG}
Stand-by current	I_{SC}	—	0.6	1	mA	PWM= 0V
Regulator voltage	V_{REG}	2.85	3.0	3.15	V	
Oscillator						
OSC pin charge current	I_{OSCC}	—	-12	—	μA	OSC pin= 0.3V
OSC pin discharge current	I_{OSCD}	—	12	—	μA	OSC pin= 1.5V
PWM, F/R input						
Input H level	V_{PWMH}/V_{FRH}	2.5	—	V_{CC}	V	
Input L level	V_{PWML}/V_{FRL}	0	—	0.8	V	
PWM input frequency	F_{PWM}	20	—	50	kHz	
Output						
Output ON resistance	$R_{ON}(H+L)$	—	1.5	2.1	Ω	$I_0=300\text{mA}$ High and Low total
FG/RD low voltage	V_{FGL}/V_{RDL}	—	—	0.4	V	$I_{FG/RD} = 3\text{mA}$
FG/RD leakage current	I_{FGH}/I_{RDH}	—	—	10	μA	$V_{FG/RD} = 15\text{V}$
Lock protection						
Lock detection ON time	T_{ON}	0.7	1	1.3	sec	$T_{ON} = \text{start time} + \text{lock detect}$
Lock detection OFF time	T_{OFF}	3.5	5	6.5	sec	
Soft start						
Soft start release voltage	V_{CSOFT}	1.5	2.0	2.5	V	
Soft start charge current	I_{CSOFT}	—	0.5	—	μA	
Current limiter						
Current limit voltage	V_{RNF}	0.2	0.25	0.3	V	
Thermal						
Thermal shutdown	ThSD	150	170	—	$^\circ\text{C}$	*1
Thermal shutdown hysteresis	ΔThSD	—	25	—	$^\circ\text{C}$	*1

*1: It is design target, not to be measured at production test.

● **Block Diagram**

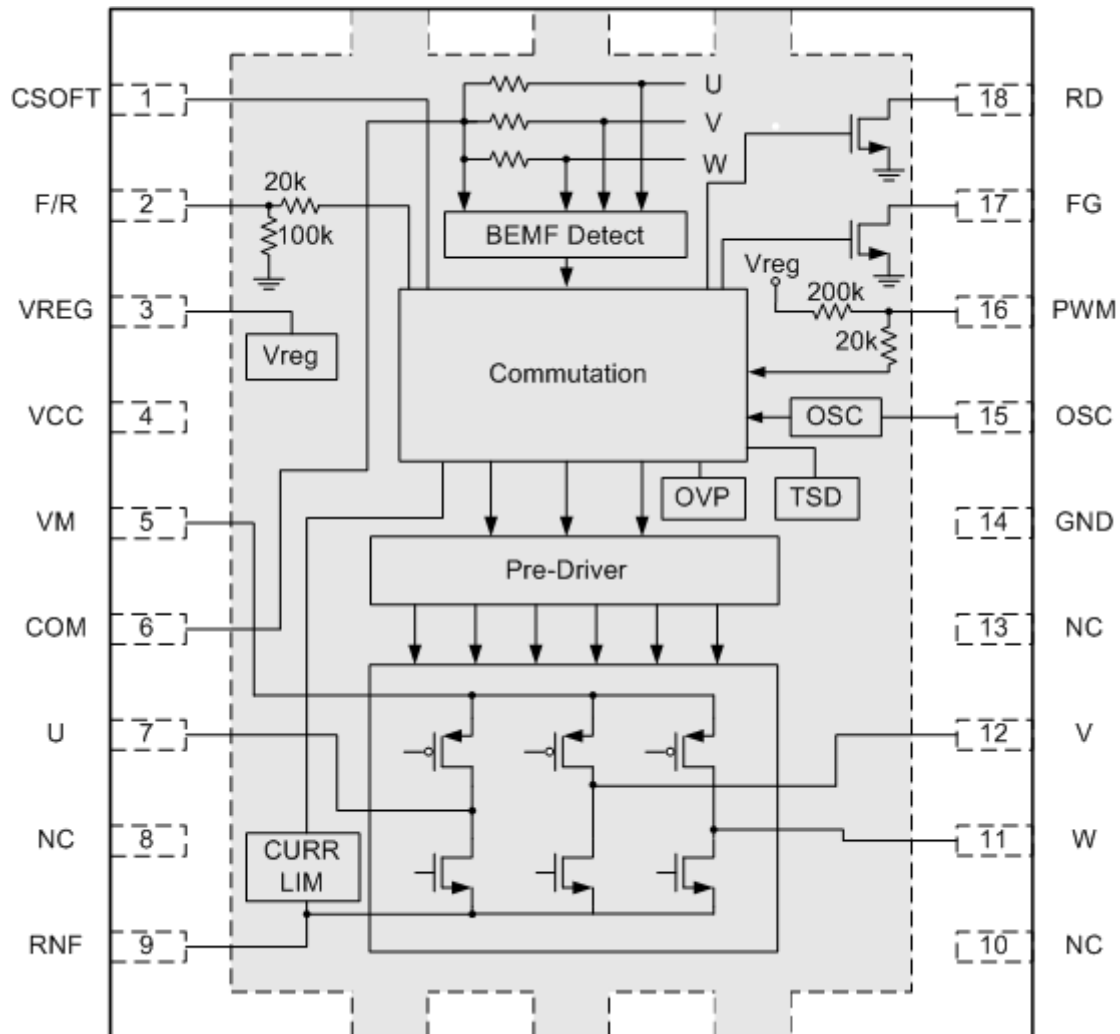

Fig.1 Block diagram

● **Pin Description**

PIN No	Pin Name	Function	PIN No	Pin Name	Function
1	CSOFT	Soft start time setting terminal	10	NC	No connection
2	F/R	Forward and Reverse control terminal	11	W	W phase output terminal
3	VREG	Regulator voltage output terminal	12	V	V phase output terminal
4	VCC	Power supply terminal	13	NC	No connection
5	VM	Output supply terminal	14	GND	Ground terminal
6	COM	Motor center tap voltage input terminal	15	OSC	Start-up frequency output terminal
7	U	U phase output terminal	16	PWM	PWM signal input terminal
8	NC	No connection	17	FG	FG signal output terminal
9	RNF	output current detection terminal	18	RD	RD signal output terminal
E-pad	PG	Power ground terminal			

● Application circuit

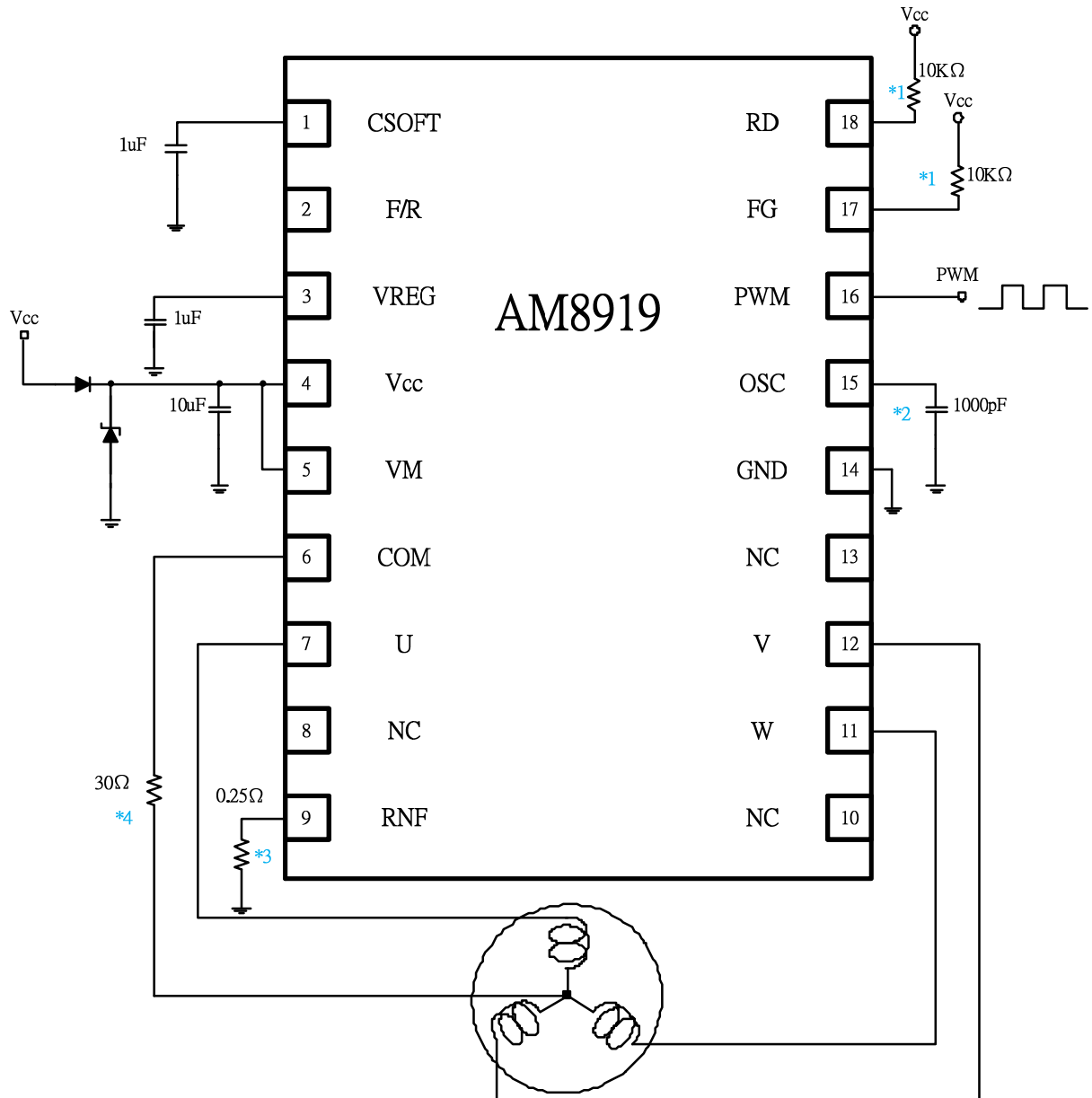

Fig.2 Application circuit

- *1 Open drain output. A pull-up resistances of 10kΩ should be inserted.
- *2 This Capacitor 1000pF is only for reference. Variable Motors should select suitable capacitor for optimum start-up characteristics.
- *3 Current limiter voltage setting is 0.25V(Typ). The formula is $RNF=0.25V/\text{current limit target}$. ($0.25\Omega=0.25V/1A$)
- *4 Need to add a 30Ω resistor between Fan and IC Com Pin.

● **Thermal Information**

Θ_{ja}	junction-to-ambient thermal resistance	32.98°C/W
Ψ_{jt}	junction-to-top characterization parameter	0.82°C/W

- **Θ_{ja}** is obtained in a simulation on a JEDEC-standard 2s2p board as specified in JESD-51.
- The **Θ_{ja}** number listed above gives an estimate of how much temperature rise is expected if the device was mounted on a standard JEDEC board.
- When mounted on the actual PCB, the **Θ_{ja}** value of JEDEC board is totally different than the **Θ_{ja}** value of actual PCB.
- **Ψ_{jt}** is extracted from the simulation data to obtain **Θ_{ja}** using a procedure described in JESD-51, which estimates the junction temperature of a device in an actual PCB.
- The thermal characterization parameter, **Ψ_{jt}**, is proportional to the temperature difference between the top of the package and the junction temperature. Hence, it is useful value for an engineer verifying device temperature in an actual PCB environment as described in JEDEC JESD-51-12.
- When Greek letters are not available, **Ψ_{jt}** is written Psi-jt.
- Definition:

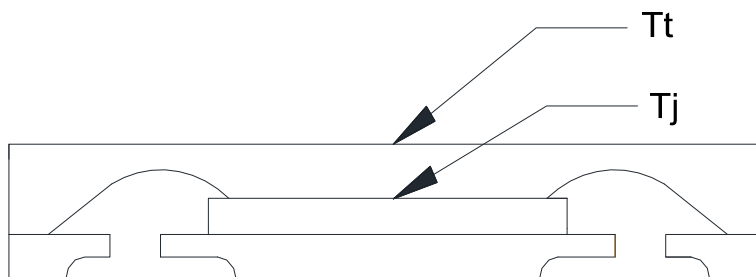

$$\text{DEFINITION: } \Psi_{jt} = (T_j - T_t) / P_d$$

Where :

Ψ_{jt} (Psi-jt) = Junction-to-Top(of the package) °C/W

T_j= Die Junction Temp. °C

T_t= Top of package Temp at center. °C

P_d= Power dissipation. Watts

- Practically, most of the device heat goes into the PCB, there is a very low heat flow through top of the package, So the temperature difference between **T_j** and **T_t** shall be small, that is any error caused by PCB variation is small.
- This constant represents that **Ψ_{jt}** is completely PCB independent and could be used to predict the **T_j** in the environment of the actual PCB if **T_t** is measured properly.

- **How to predict Tj in the environment of the actual PCB**

Step 1 : Used the simulated Ψ_{jt} value listed above.

Step 2 : Measure Tt value by using

- **Thermocouple Method**

We recommend use of a small ~40 gauge(3.15mil diameter) thermocouple. The bead and thermocouples wires should touch the top of the package and be covered with a minimal amount of thermally conductive epoxy. The wires should be heat-insulated to prevent cooling of the bead due to heat loss into wires. This is important towards preventing “too cool” Tt measurements, which would lead to the calculated Tj also being too cool.

- **IR Spot Method**

An IR Spot method should be utilized only when using a tool with a small enough spot area to acquire the true top center “hot spot”.

Many so-called “small spot size” tools still have a measurement area of 0~100+mils at “zero” distance of the tool from the surface. This spot area is too big for many smaller packages and likely would result in cooler readings than the small thermocouple method. Consequently, to match between spot area and package surface size is important while measuring Tt with IR sport method.

Step 3 : calculating power dissipation by

$$P \cong (VCC - |V_{o_Hi} - V_{o_Lo}|) \times I_{out} + VCC \times I_{cc}$$

Step 4 : Estimate Tj value by

$$T_j = \Psi_{jt} \times P + T_t$$

Step 5: Calculated Θ_{ja} value of actual PCB by the known Tj

$$\Theta_{ja}(\text{actual}) = (T_j - T_a) / P$$

Maximum Power Dissipation (de-rating curve) under JEDEC PCB & actual PCB

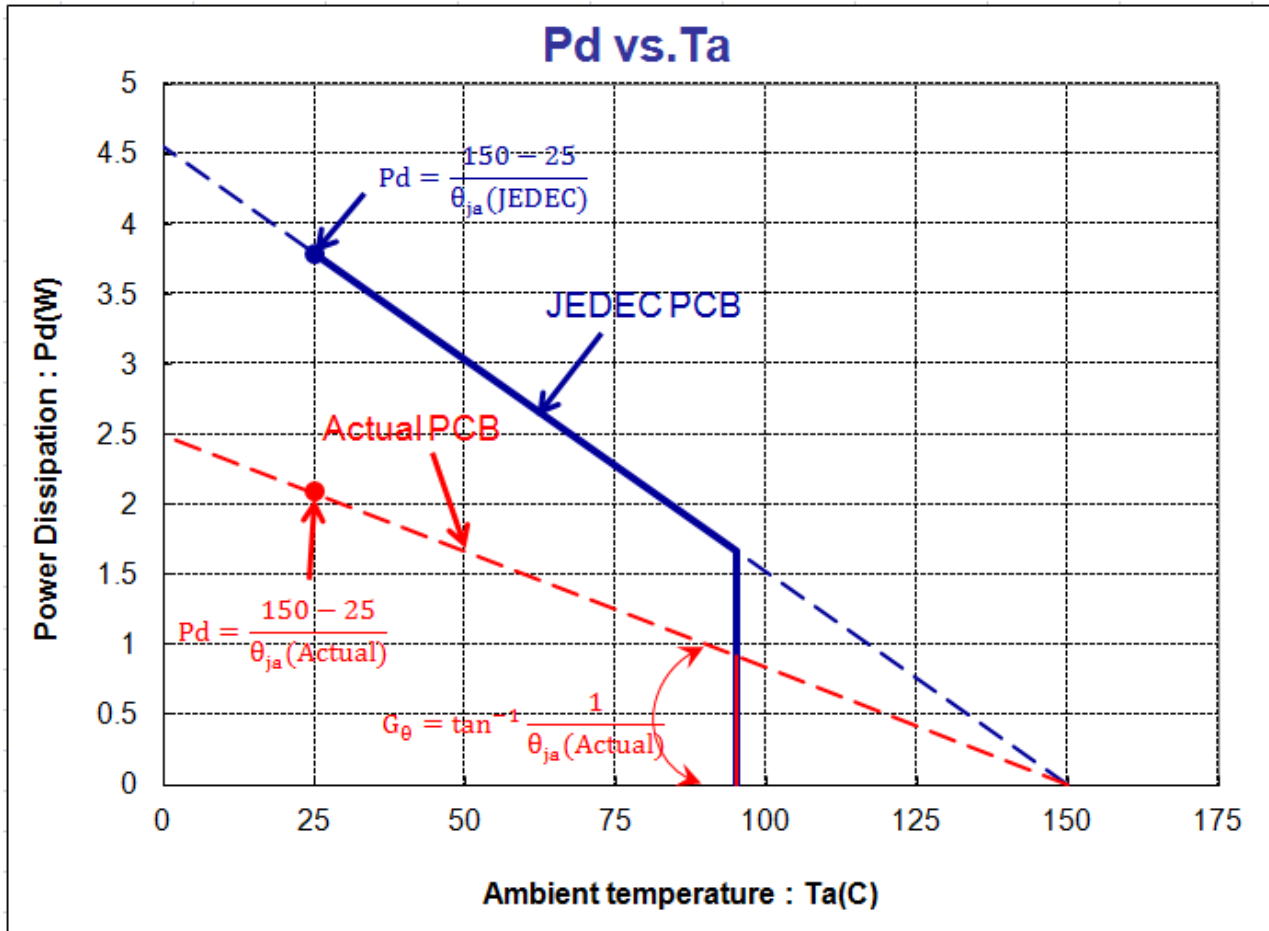

● Operation notes**1) VCC power supply line**

The BEMF causes re-circulate current to power supply. Please connect a capacitor between power supply VCC pin and ground as a route of re-circulate current. And please determine the capacitance after confirmation that the capacitance does not causes any problems.

2) VM power supply line

VM pin is U/V/W output transistors supply source. Please connect with VCC pin and short the path as possible.

3) VREG regulator

VREG is voltage regulator output and internal circuits used. Connect capacitors to ground for stable operation.

4) Ground potential

Ground potential E-PAD and GND pin connect the lowest voltage on the chip and short the path as possible.

5) PWM speed control

This IC offer PWM pin direct control output transistors for motor speed control. Higher frequency will reduce output current noise. The control input frequency recommended operation between 20 KHz to 50 KHz. If frequency is slower than 7 KHz (typ.), it will go into stand-by mode.

This pin connects internal pull-high resistance of 200K ohm to VREG. When connect to VREG or floating. The motor will rotate in the full speed.

6) Soft Switching Circuits

This IC use duty-variable switching for low acoustic noise and vibration.

7) Start-up Circuits

The OSC pin is defined a sensor-less start-up commutation frequency. The connecting capacitor is between the OSC pin and ground. Variable Motors start-up characteristic are variable with different capacitors. Variable Motors should select suitable capacitor for optimum start-up characteristics. If the capacitance value is larger, the variation start-up time is longer.

Also, if the capacitance value is smaller, the motor start-up time is shorter and might cause start-up failed by fan friction.

8) FG / RD function

This FG or RD pin is made up with an open drain output. Recommend connect a resistance of 10k ohm to supply.

9) Thermal design and Thermal shutdown

The thermal design should allow enough margins for actual power dissipation. In case the IC is left running over the allowable loss, the junction temperature rises, and the thermal-shutdown circuit works at the junction temperature of 170°C (typ.) (the outputs of all the channels are turned off). When the junction temperature drops to 145°C (typ.), the IC start operating again.

10) F/R (Forward and Reverse) function

Motor direction can be forward or reverse by switching F/R voltage level.

F/R high (VREG): U -> V-> W and F/R low (ground): U->W->V.

Internal pull low resistor is 100k ohms.

11) Current limiter

Current limiter voltage setting is 0.25V. Connect resistance to ground to determine the current limit value. The resistance path needs wider and ground side make shorter to GND.

The formula is $R_{NF} = 0.25V / \text{current limit target}$. ($0.25\Omega = 0.25V / 1A$)

12) Soft start function

The motor could be smoothly start-up when Soft start pin connecting a capacitor to ground. The function release when the voltage reaches 2.0V or more. If the soft start function is not used, keeps this pin floating.

● Packaging outline --- DFN 4x4

Unit : mm

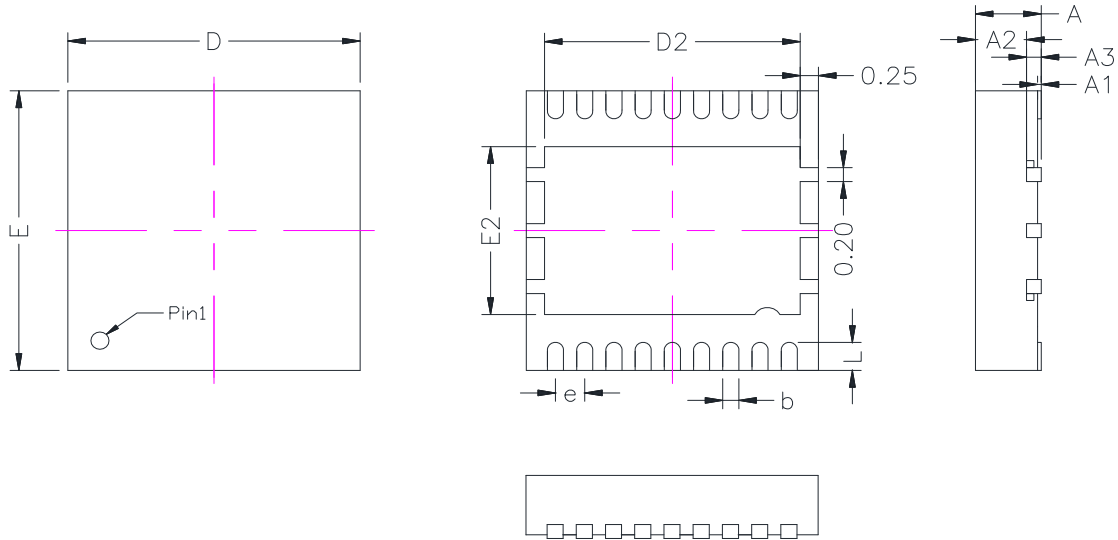

reference JEDEC MO229(D)VJGD-2

SYMBOL	MILLIMETERS		INCHES	
	Min.	Max.	Min.	Max.
A	-	0.90	-	0.035
A1	-	0.05	-	0.002
A2	-	0.70	-	0.028
A3	0.20 REF		0.008 REF	
b	0.15	0.27	0.006	0.011
D	4.00 BSC		0.157 BSC	
E	4.00 BSC		0.157 BSC	
D2	3.45	3.55	0.136	0.140
E2	2.35	2.45	0.093	0.096
L	0.35	0.45	0.014	0.018
e	0.4 BSC		0.016 BSC	

● **Condition of Soldering**

1).Manual Soldering

Time / Temperature \leq 3 sec / $400 \pm 10^\circ\text{C}$ (1 Cycle)

Test Results : 0 fail/ 22 tested

Manual Soldering count : 2 Times

2).Re-flow Soldering (follow IPC/JEDEC J-STD-020D)

Classification Reflow Profile

Profile Feature	Pb-Free Assembly
Average ramp-up rate (T_L to T_P)	$3^\circ\text{C}/\text{second}$ max.
Preheat	
- Temperature Min ($T_{s\ min}$)	150°C
- Temperature Max ($T_{s\ max}$)	200°C
- Time (ts) from ($T_{s\ min}$ to $T_{s\ max}$)	60-120 seconds
$T_{s\ max}$ to T_L	
- Temperature Min ($T_{s\ min}$)	$3^\circ\text{C}/\text{second}$ max.
Time maintained above:	
- Liquid us temperature (T_L)	217°C
- Time (t_L) maintained above T_L	60-150 seconds
Peak package body temperature (T_P)	$260 +0/-5^\circ\text{C}$
Time with 5°C of actual Peak	30 seconds
- Temperature (t_p)	
Ramp-down Rate	$6^\circ\text{C}/\text{second}$ max.
Time 25°C to Peak Temperature	8 minutes max.

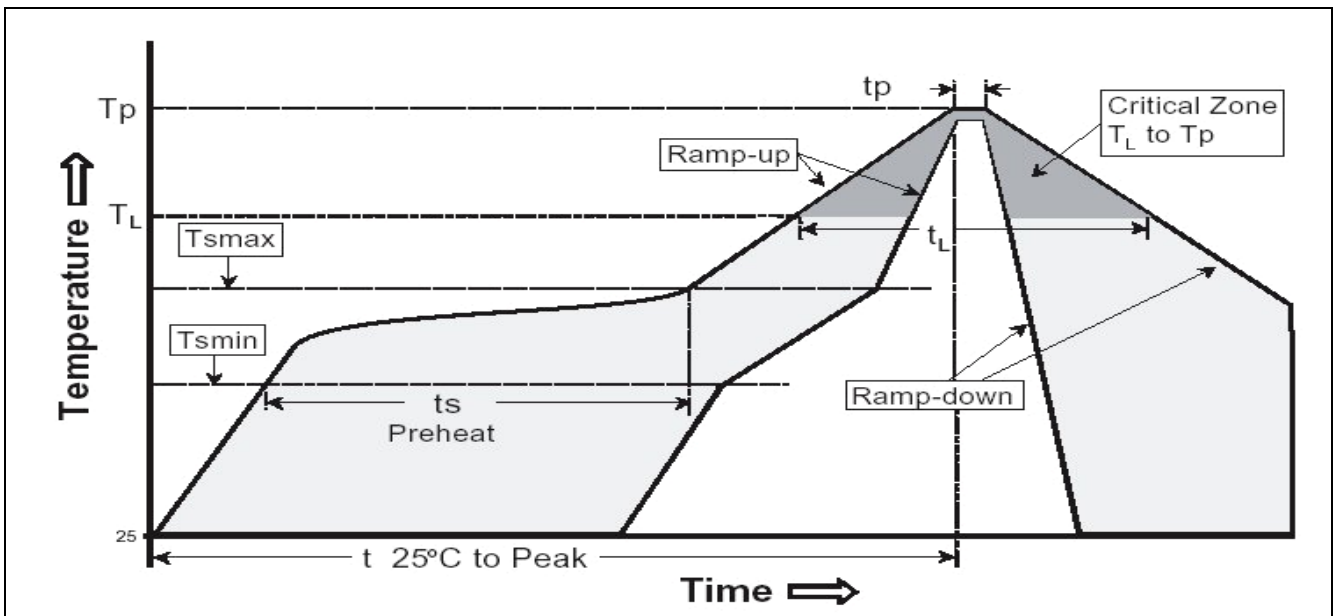

Test Results : 0 fail/ 32 tested Reflow count : 3 cycles

● **Marking Identification**

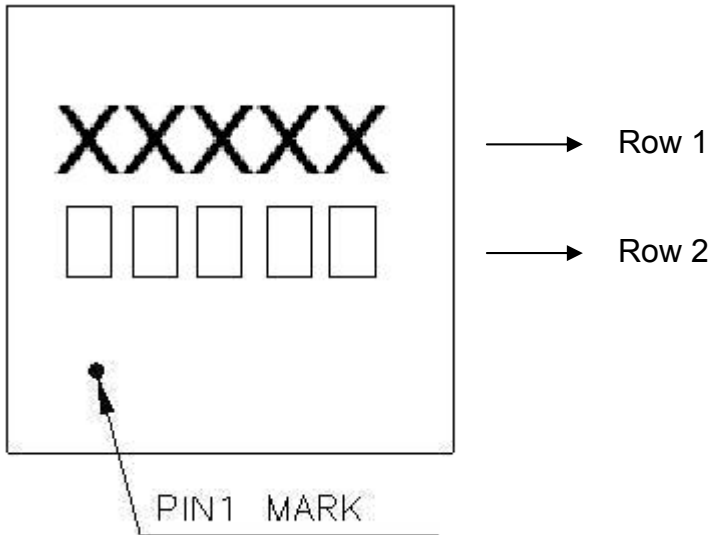

Row 1
A8919

Row 2
Lot number & Date

